

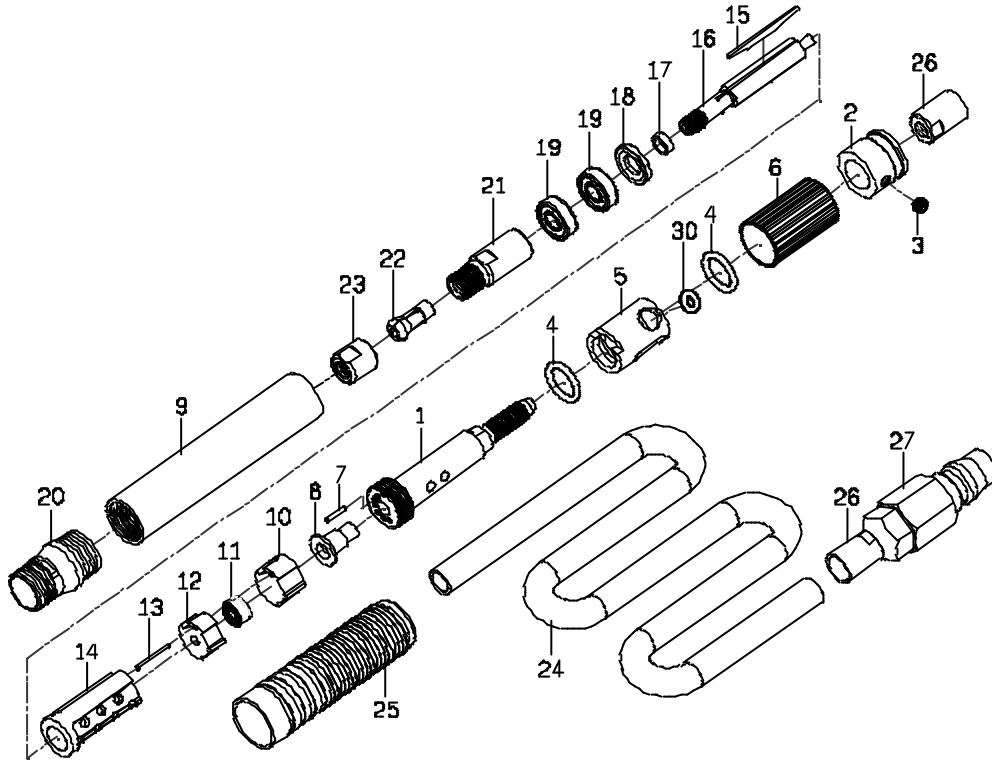

吉生 GISON

GP-8243 Air Micro Grinder



PARTS LIST

✧ : Consuming Part

Item No.	Part No.	Description	Qty.	Item No.	Part No.	Description	Qty.
1	824301	Hose Plug	1	16	824316	Rotor	1
2	824302	Rear End Holder	1	17	824317	Lateral Disc	1
3	824303	Screw	1	18	824318	Spacer	1
✧ 4	824304	O-Ring	2	✧ 19	824319	Ball Bearing	2
5	824305	Bushing	1	20	824320	Front Pipe	1
6	824306	Sliding Knob	1	21	824321	Chuck Stand	1
7	824307	Pin	1	✧ 22	824322	Collet	1
8	824308	Intake Steel Tube	1	23	824323	Clamping Nut	1
9	824309	Sleeve	1	24	824324	Air Hose (150 cm)	1
10	824310	Intake Plate	1	25	824325	Muffler Tube (40 cm)	1
✧ 11	824311	Ball Bearing	1	26	824326	Hose Ring	2
12	824312	Bearing Plate	1	27	824327	Inlet Connector	1
13	824313	Pin	1	30	824330	O-Ring	1
14	824314	Cylinder	1	31	824331	Spanner	2
✧ 15	824315	Rotor Blade	3				

Application: Ideal for grinding metal model, grinding the teeth of model, machine processing, engrave wood, gold processing and parts processing.

Please read follows carefully before operating:

1. Avoid heavy power impact to damage the precious Front Chuck.
2. To get the Abrasive Wheel tighten, please use wrench to turn reverse side everytime before operation.
3. Before operation, please be sure the Rotary Mounted Point is straight.
4. Always wear Safety Goggles to guard against eye injury cause be flying particles.
5. Suggest to use light density, non-detergent lubricant oil (i.e. #60).
6. Applicable to air working pressure 0~90 psig, regular speed: **60,000 RPM**.

Maintenance:

Do not try disassemble an airmotor by yourself, because it requires skillful person to maintain the tools. Repairing cost will be charged even it is during a term of gurantee, if the tool exposed rust or no trace of lubricant on a cylinder during the course of normal repair.

Ball Bearings:

A proper break in operation given to a new grinder during its initial use with such low pressure as 50~55 psi for the first 2~3 hours will favor to the grinder for its longer span of service afterwards.