

吉生 GISON

GP-845B Straight Line Sander (Small Type)

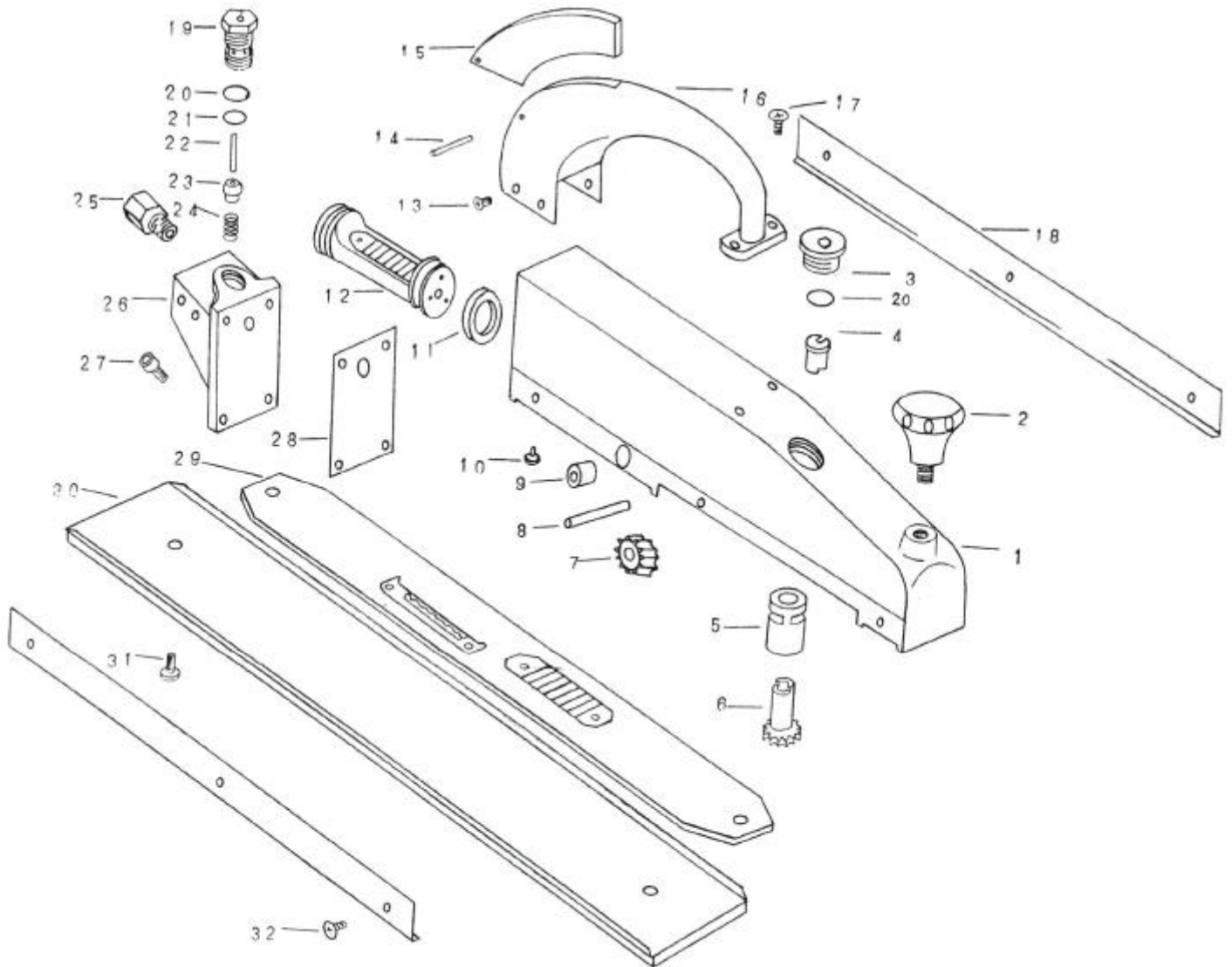

PARTS LIST

✳ : Consuming Part

Item No.	Part No.	Description	Qty.	Item No.	Part No.	Description	Qty.
1	845B01	Body Assembly	1	17	845B17	Philips Rd. Hd. Sor.	2
2	845B02	Front Handle	1	18	845B18	Side Straoe	2
3	845B03	Plunger	1	19	845B19	Valve	1
4	845B04	Adj. Shaft	1	20	845B20	O-Ring	2
5	845B05	Actuator Valve	1	21	845B21	O-Ring	1
6	845B06	Actuator Gear	1	22	845B22	Switch Control Bat	1
7	845B07	Gear	1	23	845B23	Valve Block	1
8	845B08	Shaft	1	24	845B24	Spring	1
9	845B09	Needle Bearing	2	25	845B25	Hose Adapter	1
10	845B10	Wear Button	6	26	845B26	Rear Head	1
11	845B11	Piston Ring	2	27	845B27	Socket Cap Scr.	4
12	845B12	Piston	1	28	845B28	Parking	1
13	845B13	Flat Headle Sor.	4	29	845B29	Carrier Assembly	1
14	845B14	Roll Pin	1	30	845B30	Pad Assembly	1
15	845B15	Trigger	1	31	845B31	Philips Rd. Hd. Scr.	2
16	845B16	Handle	1	32	845B32	Philips Rd. Hd. Scr.	6