

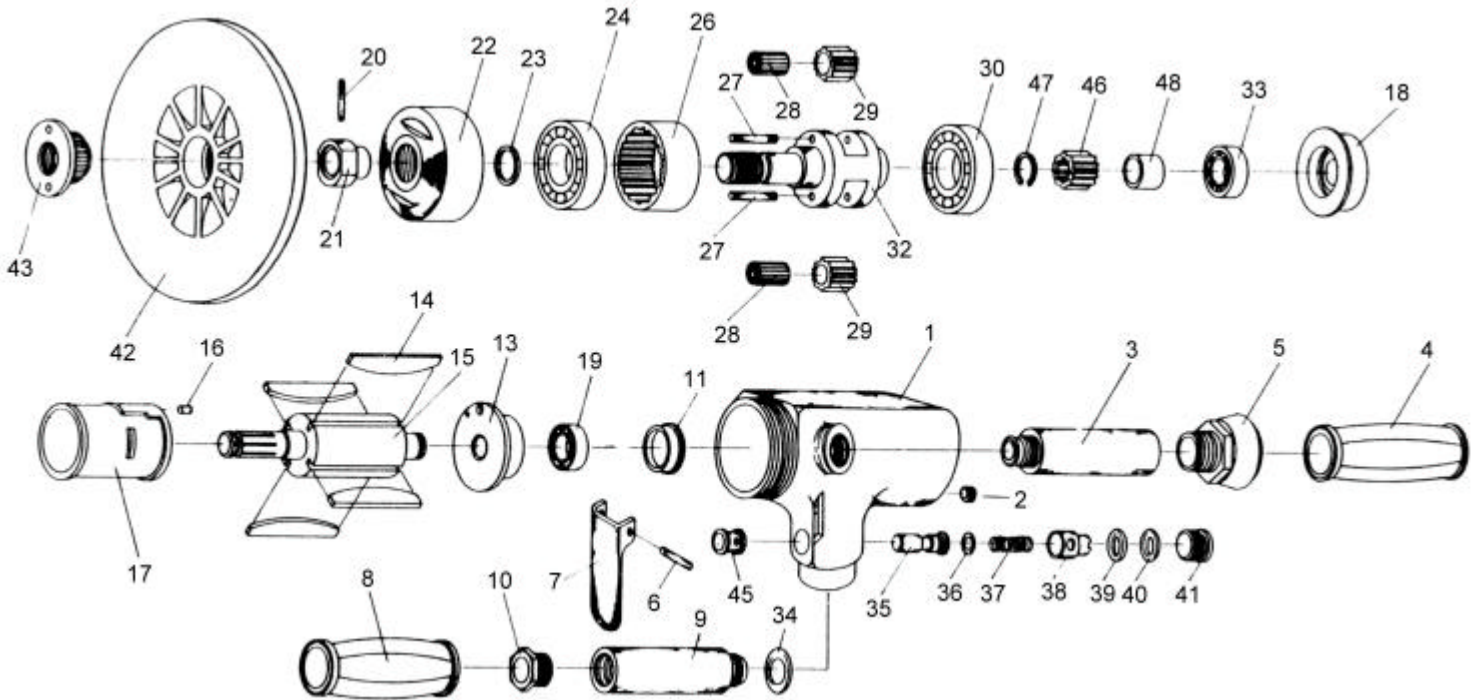

吉生 GISON

GP-821 7" Vertical Sander



PARTS LIST

✿ : Consuming Part

Item No.	Part No.	Description	Qty.	Item No.	Part No.	Description	Qty.
1	821001	Motor Housing	1	28	821028	Needle Roller	2
2	821002	Set Screw	2	29	821029	Planet Gear	22
3	821003	Exhaust Handle	1	30	821030	Ball Bearing	1
4	821004	Handle Grip (Exhaust)	1	32	821032	Planet Cage	1
5	821005	Exhaust Deflector	1	33	821033	Ball Bearing	1
6	821006	Spring Pin	1	34	821034	O-Ring	1
7	821007	Throttle Lever	1	35	821035	Valve Stem	1
8	821008	Handle Grip (Inlet)	1	36	821036	O-Ring	1
9	821009	Inlet Handle	1	37	821037	Valve Spring	1
10	821010	Inlet Bushing	1	38	821038	Air Regular	1
11	821011	Bearing Cap	1	39	821039	O-Ring	1
13	821013	Rear End Plate	1	40	821040	O-Ring	1
✿ 14	821014	Rotor Blade	4	41	821041	Valve Screw	1
15	821015	Rotor	1	42	821042	Pad	1
16	821016	Spring Pin	1	✿ 43	821043	Pad Nut	1
17	821017	Cylinder	1	45	821045	Bushing	1
18	821018	Front End Plate	1	46	821046	Sun Gear	1
19	821019	Ball Bearing	1	47	821047	External Stop Ring	1
20	821020	Spring Pin	1	48	821048	Spacer	1
21	821021	Collar	1	49	821049	Wrench	1
22	821022	Clamp Nut	1	50	821050	Wrench	1
23	821023	Oil Seal	1	K01	821K01	Motor Housing Kit (1,2,45)	1 set
24	821024	Ball Bearing	1	K02	821K02	O-Ring Kit (36,39,40)	1 set
✿ 26	821026	Internal Gear	1	K03	821K03	Planet Gear Kit (27,28,29)	1 set
27	821027	Planet Pin	2	K04	821K04	Cylinder Kit (16,17)	1 set

To get maximum performance and life of your tool, replace the whole set of Parts Kit (K01,2,3,4) is highly recommend.