

吉生 **GISON**

GP-511 Air Hydraulic Riveter

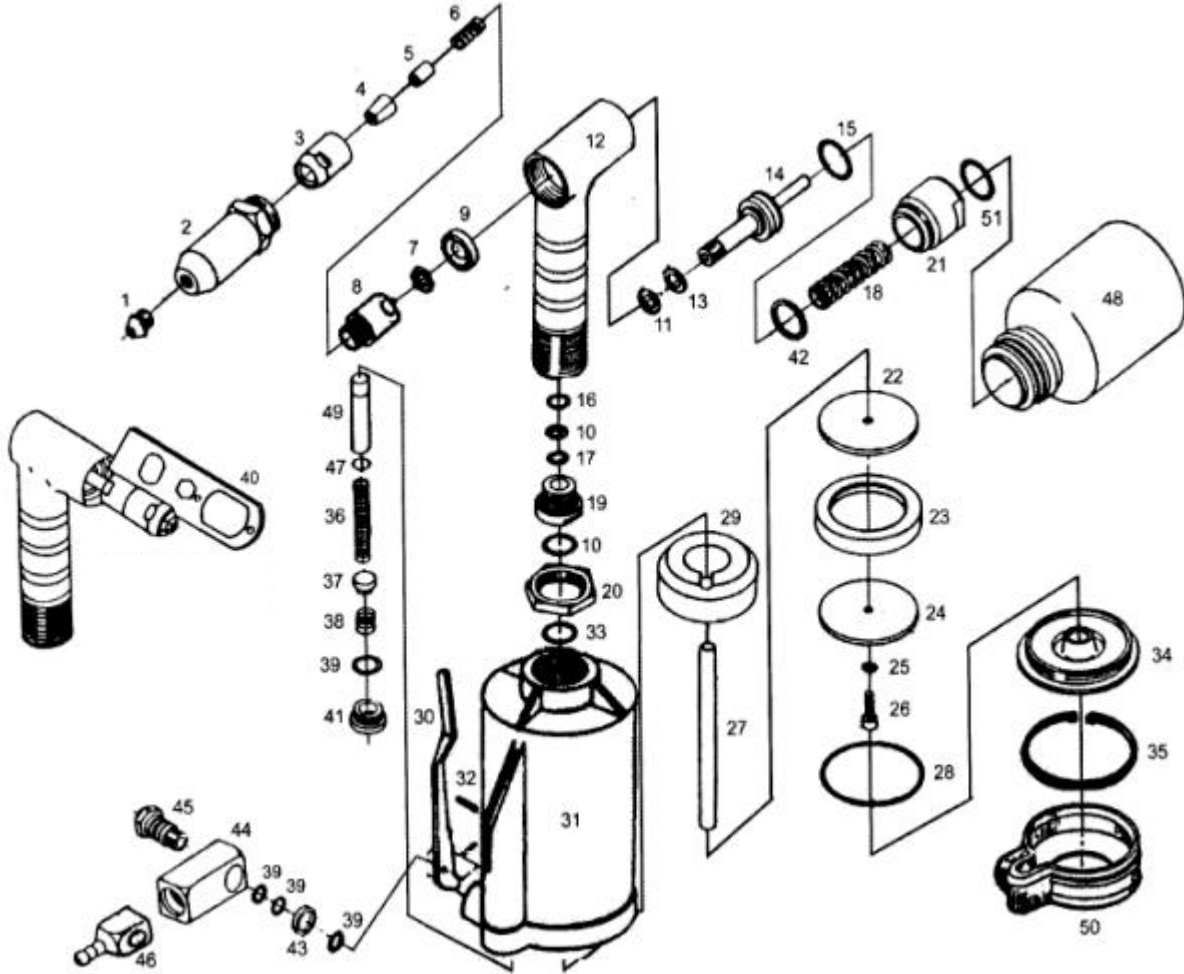

PARTS LIST

✳ : Consuming Part

Item No.	Part No.	Description	Qty.	Item No.	Part No.	Description	Qty.
1	511001	1/4" Nosepiece	1	27	511027	Plunger Rod	1
2	511002	Head	1	28	511028	O-Ring Seal	1
3	511003	Jaw Housing	1	29	511029	Damping Ring	1
4	511004	Jaws	3	30	511030	Trigger Arm	1
5	511005	Jaw Pusher	1	31	511031	Air Cylinder Body	1
6	511006	Spring	1	32	511032	Roll Pin	1
7	511007	Nut	1	33	511033	O-Ring Washer	1
8	511008	Jaw Housing Coupler	1	34	511034	Air Cylinder Cap	1
9	511009	Wiper Ring	1	35	511035	Clip	1
10	511010	X-Ring Seal	2	36	511036	Valve Pressure Spring	1
11	511011	X-Ring Washer	1	37	511037	Valve Plate	1
12	511012	Hydraulic Section	1	38	511038	Valve Tube Spring	1
13	511013	O-Ring Seal	1	39	511039	O-Ring Screw	4
14	511014	Hydraulic Plunger	1	40	511040	Wrench	1
15	511015	O-Ring Seal	1	41	511041	Screw Plug	1
16	511016	O-Ring Washer	1	42	511042	O-Ring Washer	1
17	511017	Ring Washer	1	43	511043	Sealing Washer	1
18	511018	Hydraulic Return Spring	1	44	511044	1/4" Air Inlet Fitting – (F)	1
19	511019	Hydraulic Rod Guide	1	45	511045	Air Inlet Plug	1
20	511020	Lock Nut	1	46	511046	1/4" Air Inlet Fitting – (M)	1
21	511021	Screw Plug	1	47	511047	O-Ring Seal	1
22	511022	Front Piston Head Disc	1	48	511048	Plastic Bottle	1
23	511023	Piston Head Packing Ring	1	49	511049	Valve Tube	1
24	511024	Rear Piston Head Disc	1	50	511050	Rubber Cushion	1
25	511025	Piston Head Spring Washer	1	51	511051	O-Ring Seal	1
26	511026	Piston Head Lock Screw	1				