

# GISON Pneumatic Tools

## GP-150SQH/190SQH Air Hammer (Hex.)

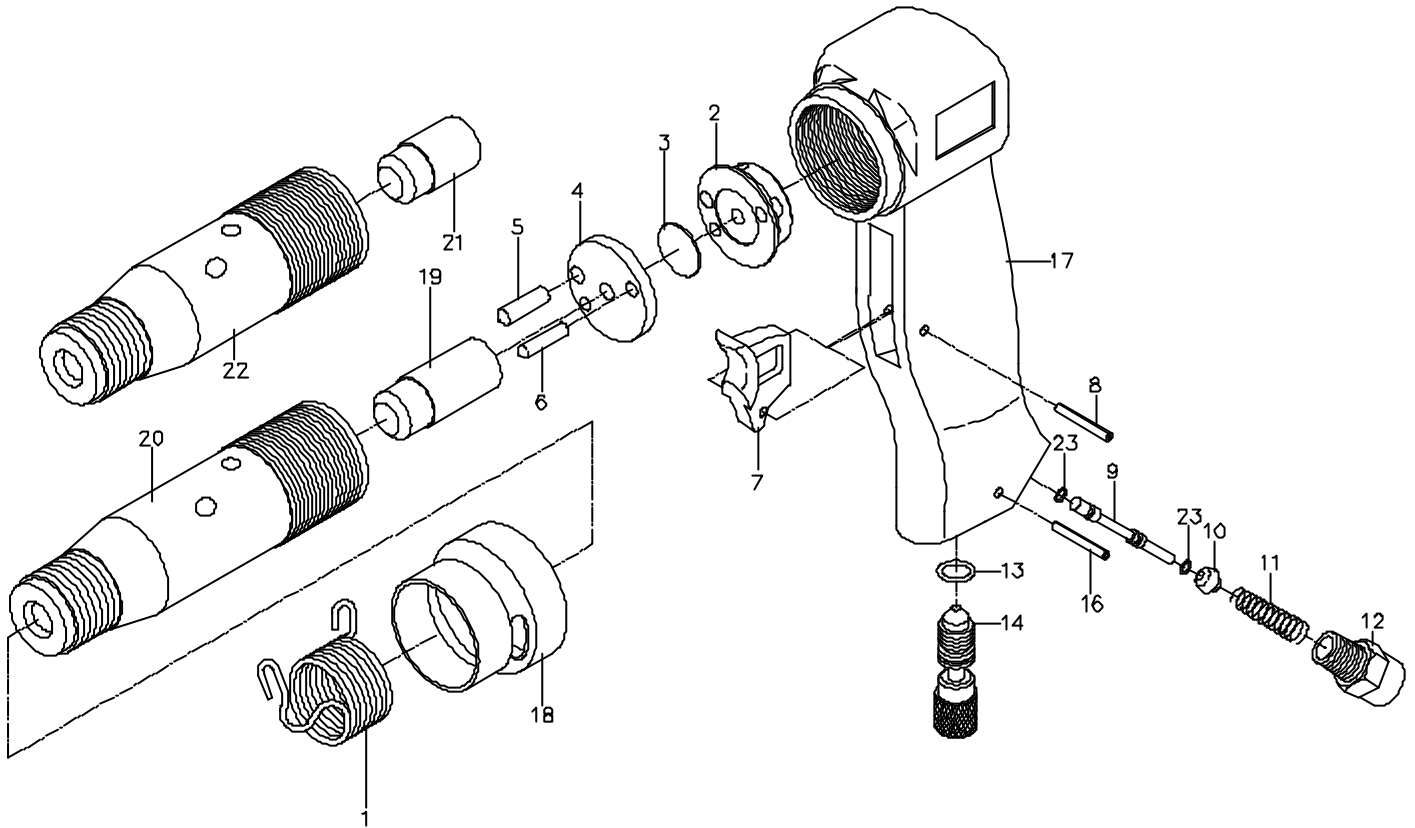

### PARTS LIST

✳ :Consuming Part

Item No.	Part No.	Description	Qty.	Item No.	Part No.	Description	Qty.
1	190SQ01	Retainer Spring	1	12	190SQ12	Throttle Cap	1
2	190SQ02	Upper Valve Seat	2	13	190SQ13	O-Ring	1
3	190SQ03	Valve Disk	1	14	190SQ14	Regulator	1
4	190SQ04	Lower Valve Seat	1	16	190SQ16	Pin	1
5	190SQ05	Dowel Pin (L)	1	17	190SQ17	Handle	1
6	190SQ06	Dowel Pin (M)	1	18	190SQ18	Exhaust Deflector	1
7	190SQ07	Trigger	1	✳ 19	190SQ19	Piston (190SQH)	1
8	190SQ08	Dowel Pin	1	20	190SQ20	Cylinder (190SQH)	1
9	190SQ09	Valve Stem	1	✳ 21	150SQ21	Piston (150SQH)	1
10	190SQ10	Valve Ball	1	22	150SQ22	Cylinder (150SQH)	1
11	190SQ11	Spring-Throttle	1	23	190SQ23	O-Ring	1

#### Features:

- .401" chisel shank opening.
- Built-in power regulator.
- Positive action trigger to control speed.
- One-piece housing design and hardened steel barrel construction for long life.
- Ideal for standard duty applications.
- An excellent general purpose hammer.

#### Applications:

Ideal for muffler and pipe removal, body shop work, shock work, scraping rust, and front end work.