

# 吉生 GISON

## GP-150/150H/190/190H/250/250H Air Hammer

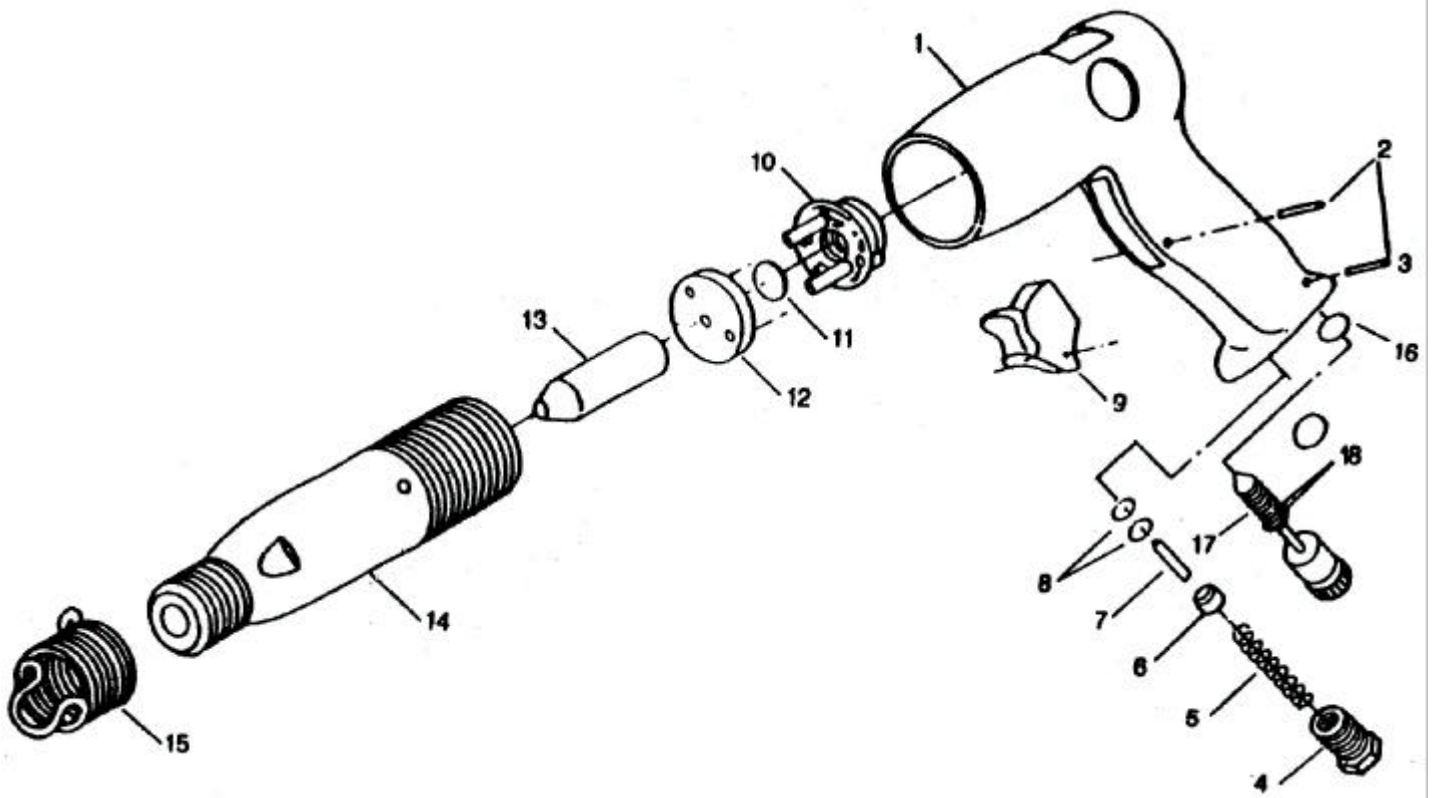

### PARTS LIST

✳ :Consuming Part

No.	Part No.	Description	Qty.	No.	Part No.	Description	Qty.
1	150001	Handle (For GP-150)	1	14	150014	Cylinder (Round-150)	1
	190001	Handle (For GP-190/250)			150H14	Cylinder (Hex.-150H)	
2	190002	Pin (Trigger)	1		190014	Cylinder (Round-190)	
3	190003	Pin (Regulator)	1		190H14	Cylinder (Hex.190H)	
4	190004	Hose Adapter	1		250014	Cylinder (Round-250)	
5	190005	Throttle Spring	1		250H14	Cylinder (Hex.250H)	
6	190006	Rubber Seat	1	15	190015	Retainer Spring	1
7	190007	Valve Stem	1	16	190016	Rubber Gasket	1
8	190008	O-Ring	1	17	190017	Regulator	1
9	190009	Trigger	1	18	190018	O-Ring	1
10	190010	Rear Valve	1	19	190019	Valve Stem Ass'y (5-8)	1 Set
11	190011	Valve Disc	1	20	190020	Valve Ass'y (10-12)	1 Set
12	190012	From Valve	1	21	190021	Regulator Ass'y (17-18)	1 Set
13	190013	Piston	1				